

# VLAZE

MODULAR FURNITURE FOR  
INDOOR & OUTDOOR LIVING







# VLAZE

MODULAR FURNITURE FOR  
INDOOR & OUTDOOR LIVING

**VLAZE ADAPT is an innovative collection of modular and freestanding furniture that can be moved freely from indoors to outside.**

Designed for outdoor living these pieces offer the perfect solution for food preparation and al fresco dining.

The kitchen modules are engineered from stainless steel and adorned with a vitreous enamel surface while the dining tables and planters use a combination of powder coated steel and vitreous enamel. This durable, weather proof enamel surface finish is guaranteed for 25 years and is created by fusing powdered glass to steel at temperatures in excess of 800°C. The result is a luxurious vibrant glaze that is heatproof, hygienic and stain resistant.

VLAZE is British made on the Isle of Wight by the makers of the iconic signage for the London Underground and the Paris Metro.





*“kitchen units that adapt to your cooking and lifestyle”*

DESIGNED FOR BEAUTY

VLAZE surfaces are uniquely inviting. The high gloss vitreous enamel is wonderfully tactile, encouraging a hands-on approach that lends creative expression to the food you love. From rolling out dough to scattering flour or drizzling olive oil, you'll find your VLAZE unit and it's durable, easy-clean surface adapting to your cooking and lifestyle.

MADE FOR ENTERTAINING

Take your dining al fresco, ADAPT units form the centrepiece to gather friends and family around. Simply wheel into position on your terrace, deck or balcony and you have the perfect station for preparing food, serving meals and hosting drinks. Ample internal storage teamed with ingenious magnetic pots mean everything is close to hand – preventing interruption to your flow.

BUILT TO LAST

It's rare that something beautiful can offer so much practical functionality. The standout build quality makes VLAZE ADAPT kitchen units beloved pieces of furniture that quickly become an indispensable part of modern outdoor living.



FOLLOW @VLAZESURFACE





VLAZE THE INSIDE OUT KITCHEN

An open plan kitchen that utilises the free moving ADAPT ISLAND and 120 ADAPT to connect the inside with the outside. The inside element of this kitchen features a fixed 240 ADAPT unit while the two movable units can be used indoors or out making for a beautifully versatile space.

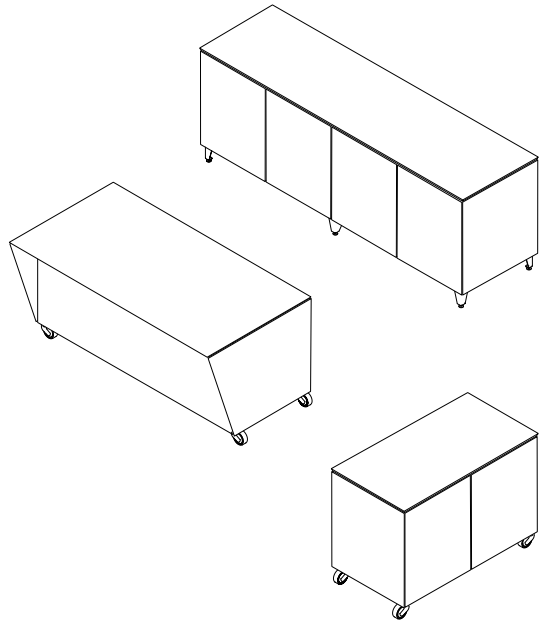

120 ADAPT C in Quilted Graphite  
ADAPT ISLAND in Indigo Stipple  
ADAPT 240 in Quilted Graphite







VLAZE THE LONDON COURTYARD

In this compact urban courtyard the 120 BARBECUE provides a space saving area dedicated to food preparation and cooking plus ample storage for kitchen equipment, utensils and fuel.

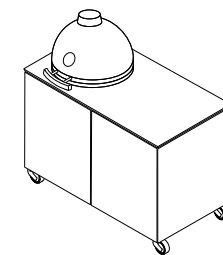

120 BARBECUE C in Quilted Graphite featuring large Big Green Egg



German engineered BLUM Onyx soft close hinges





VLAZE THE GARDEN PAVILLION

The 120 ADAPT incorporated into this outdoor living room by 2LG Studio. This versatile unit can serve as a cocktail cabinet or food preparation area creating a striking focal point for this outdoor summer pavillion.

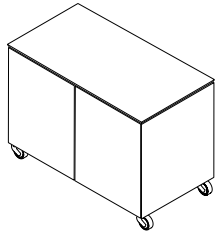

120 ADAPT C in Indigo Stipple  
Bespoke table top in matching Indigo Stipple



A luxurious surface finish that offers unrivalled practicality







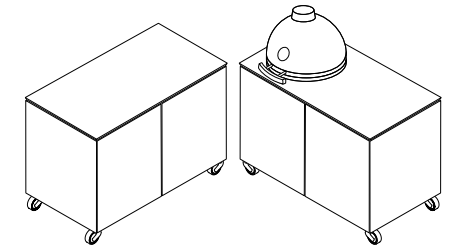

VLAZE THE KITCHEN TERRACE

The combination of a 120 ADAPT with a 120 BARBECUE creates an instant, outdoor kitchen for food preparation, cooking and entertaining.



 120 ADAPT C in Black Splatter  
120 BARBECUE C in Quilted Graphite  
featuring Big Green Egg



Ample storage and surface space for your hosting needs





VLAZE THE KITCHEN GARDEN

The ADAPT ISLAND used as the perfect pizza station in this bright kitchen garden terrace. The heat proof finish allows the pizza oven to be placed directly on the unit. The addition of a matching 120 ADAPT provides additional food and drink preparation. When not cooking outside the units can be repurposed for use indoors.

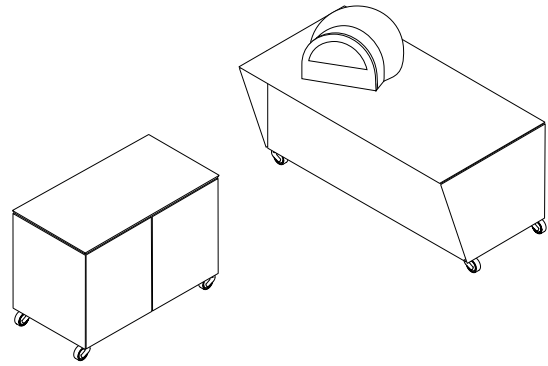

120 ADAPT C in Indigo Stipple  
ADAPT ISLAND in Indigo Stipple  
featuring DeliVita Pizza Oven



Reconfigure the units with ease; from food preparation station to mobile bar





ADAPT Magnetic Pots to keep herbs and utensils at easy reach



Heatproof surface is both beautiful and practical



Engineered 304 stainless steel carcass with sturdy shelves for those pots and pans





VLAZE VIBRANT DINING

The 240 KITCHEN GRILL unit with its integrated sink and Beefeater Grill and the free moving ADAPT ISLAND are perfectly suited to terrace dining. Together, they form a versatile kitchen and entertainment space with storage for all your needs. Allowing you to prepare delicious food and drinks, while providing a focal point capable of hosting large gatherings.

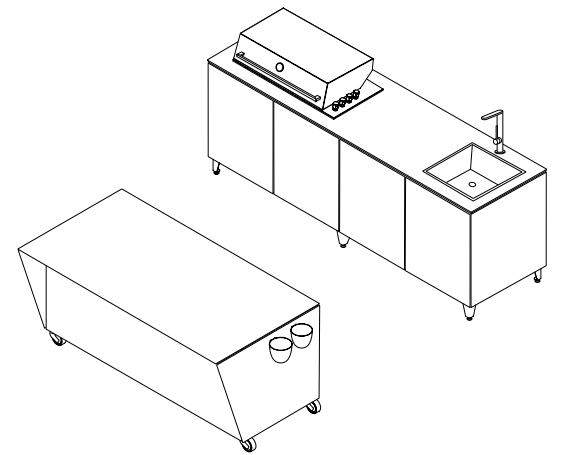

 240 KITCHEN GRILL L in Ochre  
featuring Beefeater Grill & Caple sink & tap  
ADAPT ISLAND in Ochre  
ADAPT MAGNETIC POTS in Graphite



Create a statement kitchen with bright ochre vitreous enamel





Inbuilt sink & tap makes food preparation simple meaning more time with your guests



The perfect serving station for drinks and food



240 KITCHEN GRILL equipped with a high performance Beefeater Grill





VLAZE THE COUNTRY GARDEN

A full complement of ADAPT furniture and accessories creates the perfect outdoor cooking and entertaining space in this classic Cotswolds garden. A LOW PLANTER, the 120 ADAPT, the 120 BARBECUE and the 240 KITCHEN GRILL with an integrated Beefeater Grill provides everything you need be it a meal for two or full catering for a summers evening party.

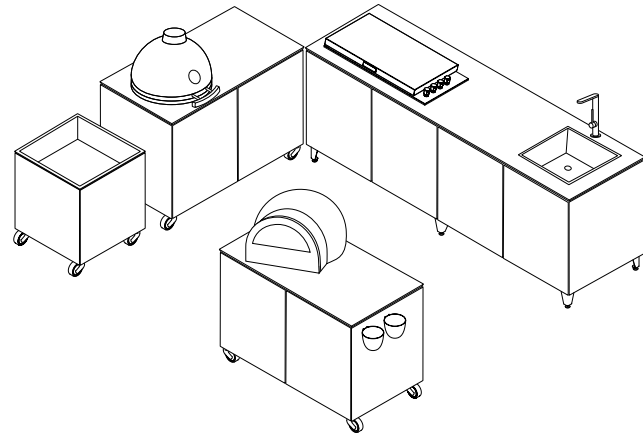

 ADAPT LOW PLANTER in Quilted Graphite  
120 ADAPT C in Quilted Graphite  
120 BARBECUE C in Quilted Graphite featuring Big Green Egg

240 KITCHEN GRILL L in Quilted Graphite  
featuring Beefeater Signature Proline® Grill & Caple sink & tap  
ADAPT MAGNETIC POTS in Graphite



A luxurious and practical surface finish



Keep those herbs at easy reach with ADAPT Magnetic Pots







Sharknose detailing for a contemporary aesthetic



Strong sturdy castors make movement effortless with a built in brake for safety



The Beefeater Slimline Grill complements the units clean lines





VLAZE THE MODULAR KITCHEN

The 120 ADAPT is used as an additional preparation and storage space for this kitchen area. The castors allow it be moved and reconfigured around the space.

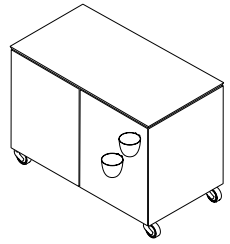

120 ADAPT C in Black Splatter



The perfect kitchen companion both inside and out







VLAZE POOLSIDE COMPANION

The 120 ADAPT, with its durable, weatherproof enamel finish and ample storage make it the perfect poolside companion. It's a versatile unit that can be moved freely to suit your lifestyle. Available in a range of stunning finishes that always bring the sunshine.

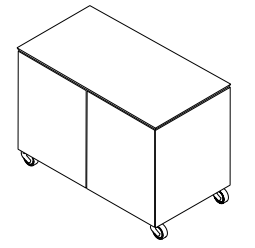

ADAPT 120 C in Indigo Stipple

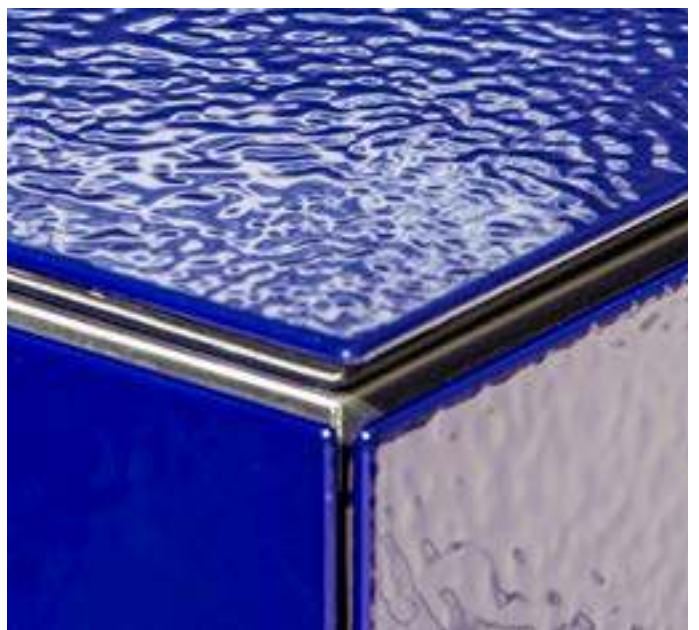

Attention to detail with crisp shut lines





VLAZE ADAPT ENTERTAINING

The ADAPT ENTERTAINING is one of our favourite suggested kitchen layouts. It offers everything you need to prepare delicious meals and serve drinks as the sun goes down. The addition of the ADAPT ISLAND gives a focal point to the kitchen and a place in which to gather your guests.

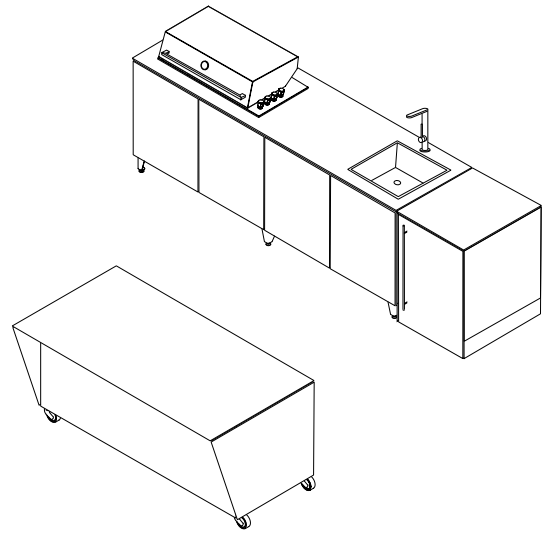

240 KITCHEN GRILL L in Ochre  
featuring Beefeater Signature Proline® Grill & Caple sink & top  
ADAPT FRIDGE in Ochre  
featuring Blastcool XP1 Fridge  
ADAPT ISLAND in Ochre



The ADAPT FRIDGE can be placed next to any ADAPT module or stand alone





# THE VLAZE ADAPT COLLECTION



## 120 ADAPT

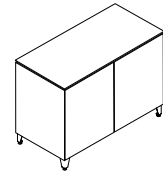

1200 x 700 x 900  
Vitreous enamel / stainless steel  
5 colour options  
2 base options (SINK legs only)

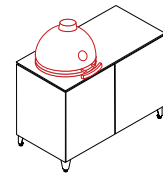

**120 BARBECUE**  
Unit designed to house large Big Green Egg\*

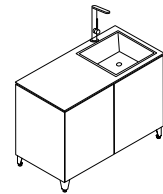

**120 SINK**  
Unit with stainless steel Caple Mode 045 sink & tap  
Leg base only

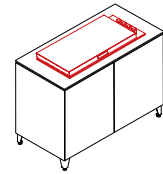

**120 GRILL**  
Unit designed to house Beefeater Signature Proline gas Grill\*

## ADAPT ISLAND

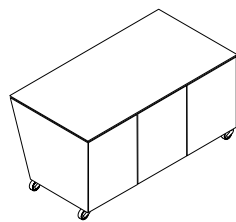

1800 x 950 x 900  
Vitreous enamel / stainless steel  
5 colour options  
Castor base only

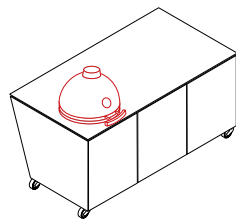

**BARBECUE ISLAND**  
Unit designed to house large Big Green Egg\*

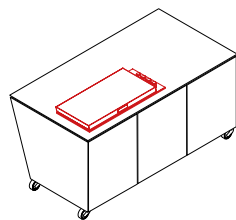

**GRILL ISLAND**  
Unit designed to house Beefeater Signature Proline gas Grill\*

## 240 ADAPT

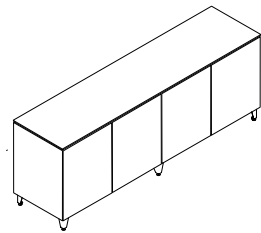

2400 x 700 x 900  
Vitreous enamel / stainless steel  
5 colour options  
2 base options

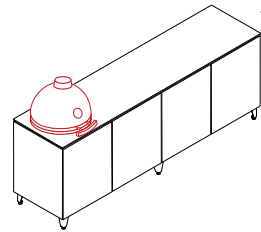

**240 BARBECUE**  
Unit designed to house large Big Green Egg\*

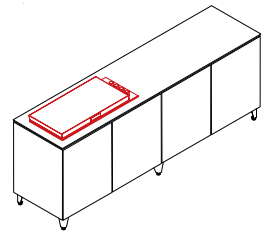

**240 GRILL**  
Unit designed to house Beefeater Signature Proline gas Grill\*

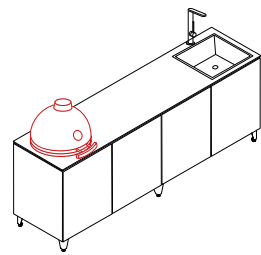

**240 KITCHEN BARBECUE**  
Unit with stainless steel Caple Mode 045 sink & tap with optional large Big Green Egg\*

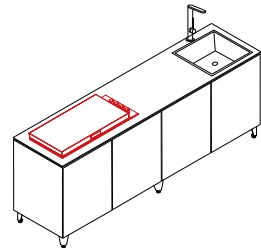

**240 KITCHEN GRILL**  
Unit with stainless steel Caple Mode 045 sink & tap with optional Beefeater Signature Proline gas Grill\*

## ADAPT FRIDGE

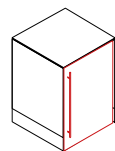

600 x 700 x 900  
Vitreous enamel / stainless steel  
5 colour options  
Unit designed to house Blastcool XP1 Fridge\*

## ADAPT PLANTER

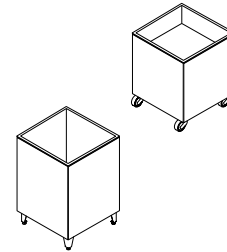

**LOW** 600 x 600 x 600  
**HIGH** 700 x 700 x 900  
Vitreous enamel / galvanised steel  
Drop-in tray options  
5 colour options  
2 base options

## ADAPT CONSTRUCTION CORNER

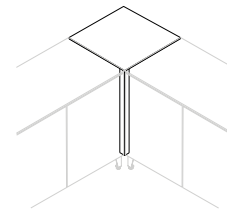

700 x 700 x 900  
Vitreous enamel / stainless steel  
5 colour options  
Create a fixed corner  
multiple options available

## ADAPT DINING TABLE

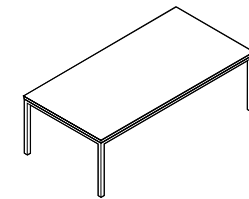

2000 x 950 x 750  
Vitreous enamel / Steel base  
5 colour options

## ADAPT BASE OPTIONS



Heavy-duty Castors (C)  
Stainless steel Legs (L)

## ADAPT ALL WEATHER COVER

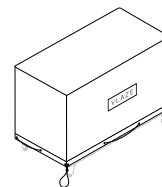

Breathable all weather cover in mid grey available for all ADAPT furniture

## ADAPT MAGNETIC POTS

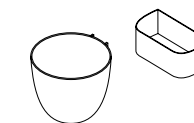

Available in 2 sizes  
in Graphite, Ivory & Buff

## ADAPT COLOUR



Quilted Graphite



Black Splatter



Indigo Stipple



Ochre



Nori

ENAMEL FINISH: VLAZE enamels are milled in-house using natural compounds and oxides therefore batches may differ slightly in colour and finish. This is part of the unique, organic character of vitreous enamel. All dimensions in mm.

\*Optional appliances sold separately

Please note: All colours have been reproduced as faithfully as print will allow. Photos should not be taken as an exact indication of colour.



## THE VLAZE ADAPT SUGGESTED LAYOUTS

### ADAPT SLIMLINE

Streamlined and perfectly formed. Everything you need to prepare delicious food and drinks while enjoying your outdoor living space.

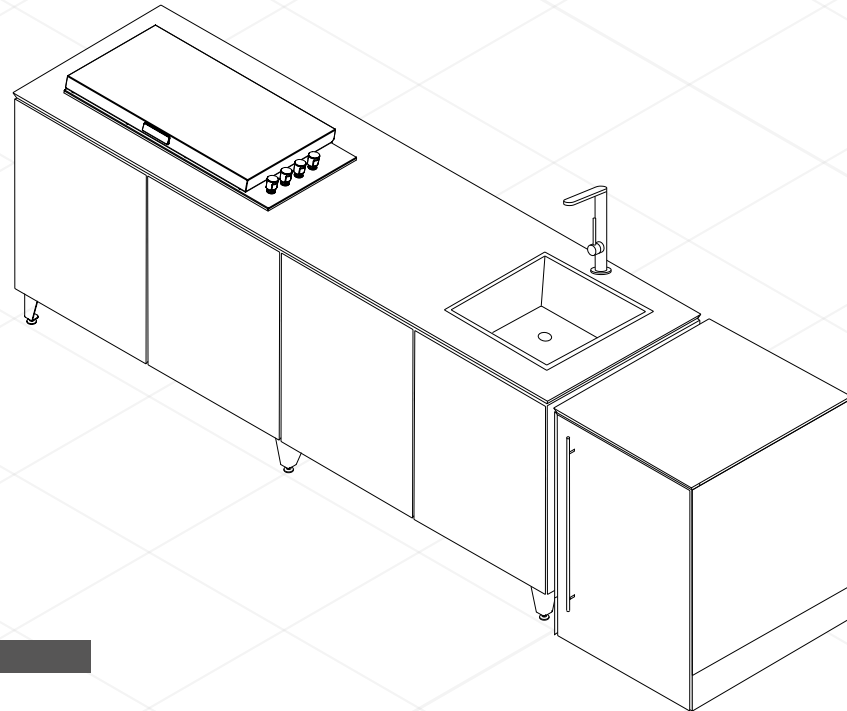

INCLUDES:

**240 KITCHEN GRILL**  
**ADAPT FRIDGE**

### ADAPT ENTERTAINING

The addition of the free moving ADAPT ISLAND provides plenty of storage as well as a dedicated seating/hosting area.

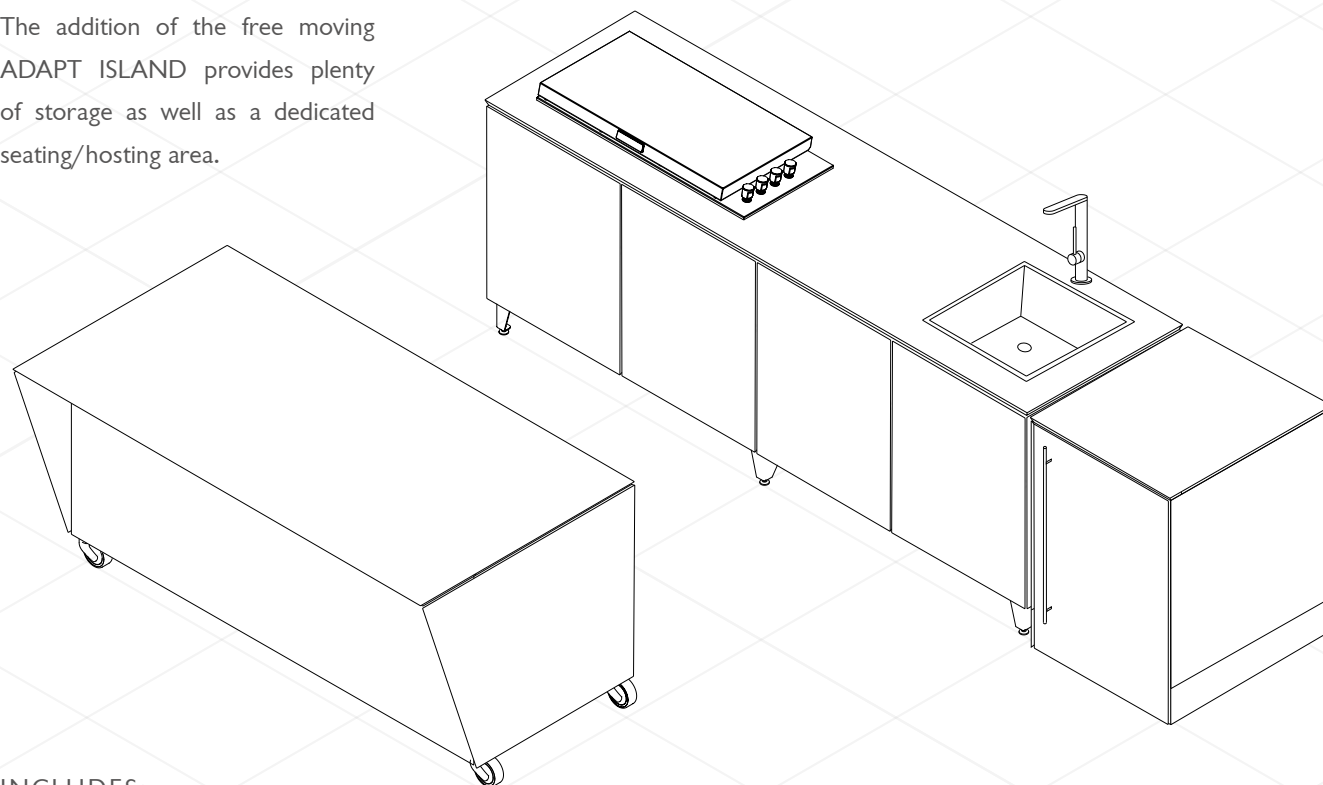

INCLUDES:

**240 KITCHEN GRILL**  
**ADAPT FRIDGE**  
**ADAPT ISLAND**

### ADAPT ULTIMATE KITCHEN

A full array of cooking options and substantial storage allows you to host large gatherings with ease.

INCLUDES:

**240 KITCHEN GRILL**  
**ADAPT FRIDGE**  
**120 BARBECUE**  
**ADAPT ISLAND**  
**CONSTRUCTION CORNER**

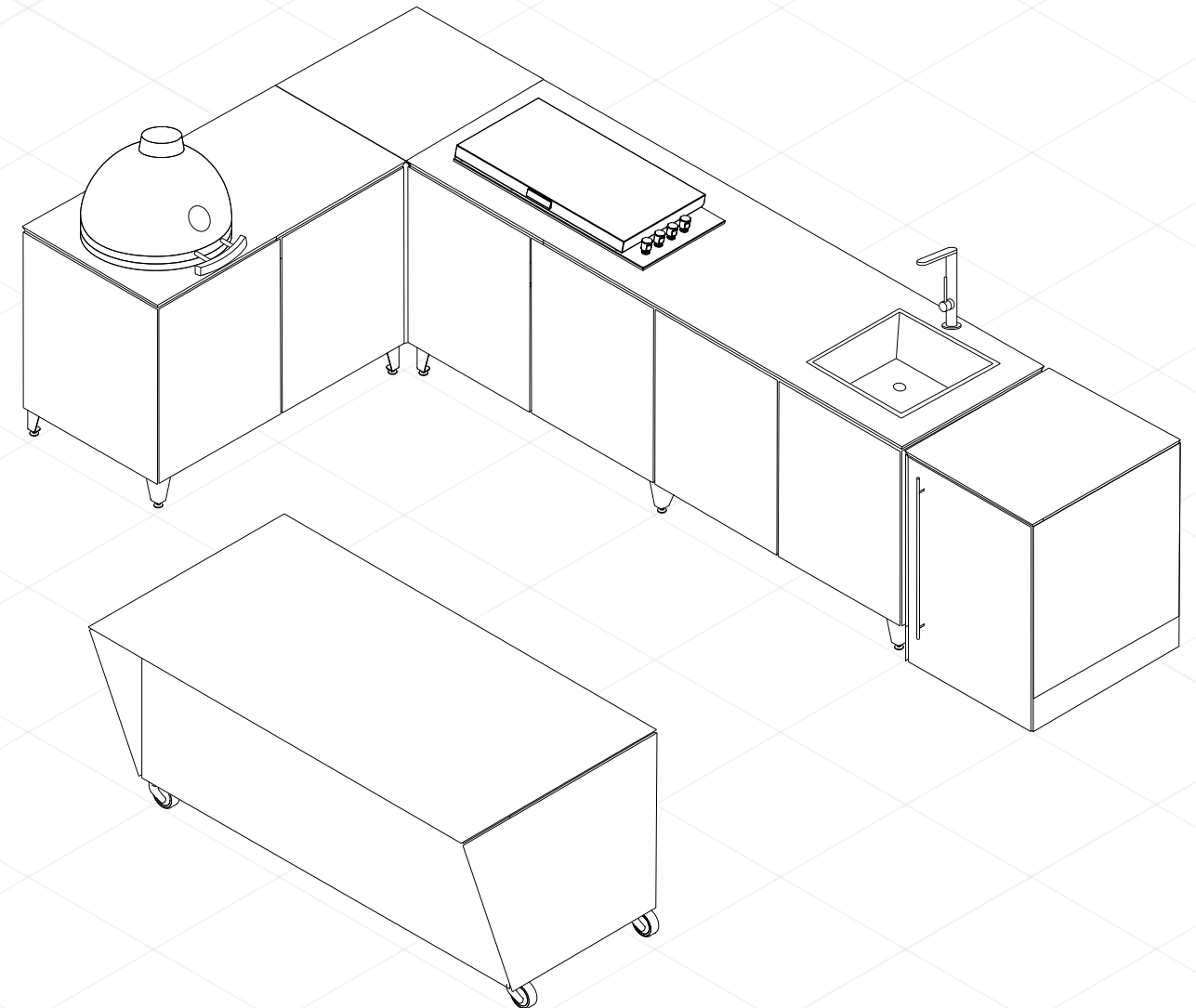



**25**  
YEAR GUARANTEE



**VLAZE** BISHOPS WAY, NEWPORT, ISLE OF WIGHT PO30 5WS, UK  
TEL: +44 (0)1983 537 773 • **VLAZE.CO** • @VLAZESURFACE

A DIVISION OF A.J.WELLS & SONS LIMITED REGISTERED IN ENGLAND NO. 03809371 • AJWELLS.COM

